

# LEKTRO

## Model AP8850SDA-AL-100

### AIRCRAFT TOWING VEHICLE

FOR AIRCRAFT UP TO 120,000 LBS/54,432 KG

1190 S.E. Flightline Drive, Warrenton, Oregon 97146-9692

1-800-535-8767 • 503-861-2288 • Fax 503-861-2283

E-mail: sales@lektro.com

http://www.lektro.com

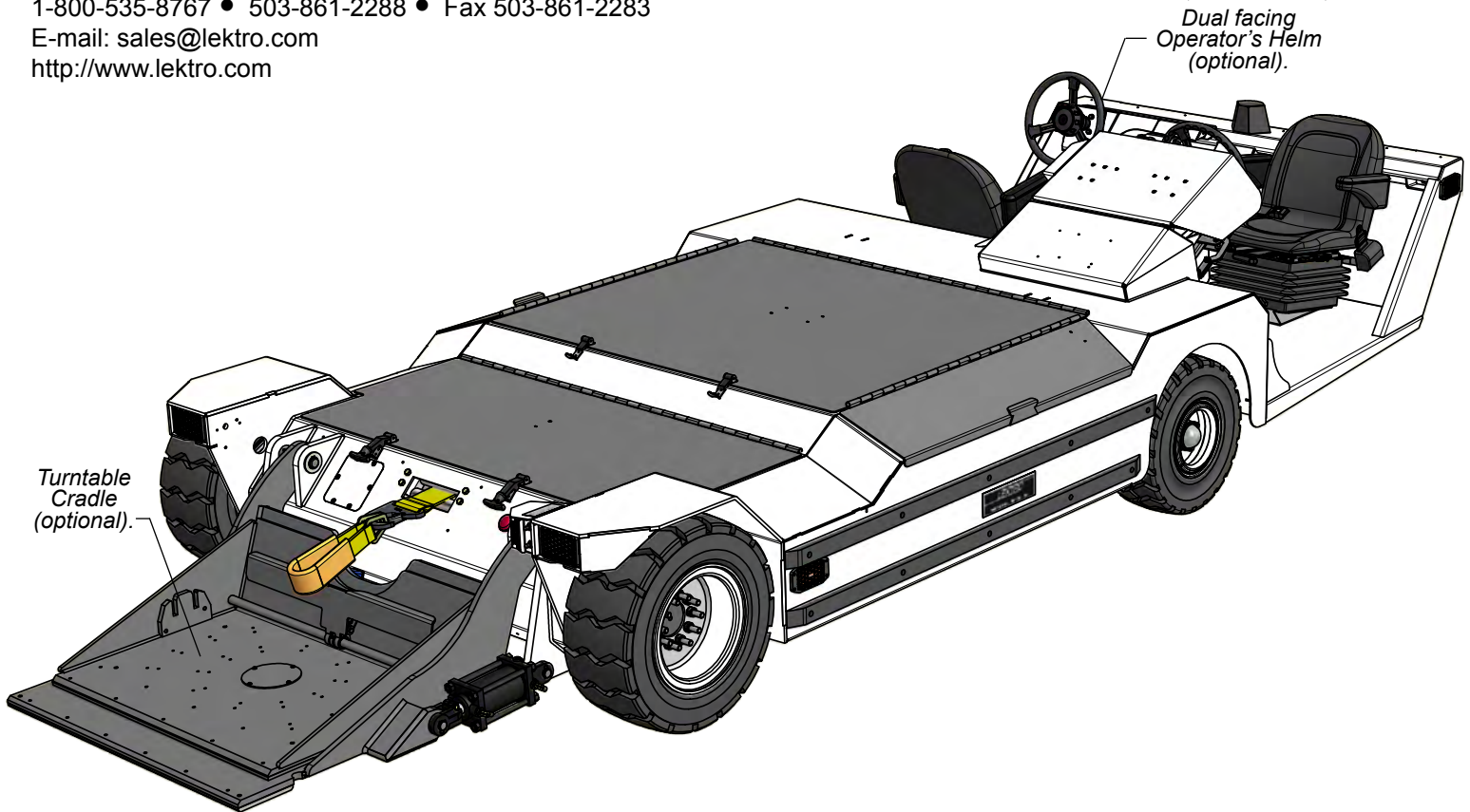

#### AP8850SDA-AL-100 FEATURES:

**Vehicle Drive:** 45.3 HP/33.8 kW, 72 VDC Traction Motor mated with Auburn/Dana 44 Differential. Limited Slip Differential, optional.

**Motor Speed Control:** EV200ZX SCR with On-Board Diagnostics. Speed controlled by Foot Throttle.

**Batteries:** Two 36 VDC Industrial, 440 AMP-HR Batteries (6 hr rate), wired in series with Single Point Watering System. 550 AH, optional.

**GPU:** Built-in Independent 12/24/28 VDC / 1175 CCA Batteries and Charging System, optional.

**Motive Battery Charger:** External Fully Automatic 90 AMP DC / 208-480 VAC / 60 Hz / 3-PH Charger. 100 AMP and/or 50 Hz, optional.

**Nose Gear Lift Cradle:** Patented Universal Nose Gear Lift Cradle activated by an Electric/Hydraulic Pump Assembly. Aircraft Selection System and Patented Torque Sensing Turntable Cradle Deck, optional.

**Winch:** Heavy-duty Hydraulic Winch with Automatic Safety Cut-Off and RH/LH Winch/Cradle fender controls. Winch and Strut Straps included.

**Steering:** Electric/Hydraulic Power Steering controlled through Automotive-type Tilt Wheel requiring minimal effort with very responsive steering action. Automatic Timer turns off power when tug not in use, increasing battery shift life.

**Service Brakes:** Foot Operated Hydraulic Disc-Type Service Brakes utilizing the final Wheel Drive Gearing to achieve maximum braking with minimal effort.

**Parking Brake:** Hand activated Electric Switch controlling Spring Applied/Hydraulic Released Calipers mounted on each Service Brake Disc.

**Drive Tires:** Single 23 x 10 x 12 Solid-Pneumatic Traction Tread. Siping, Auto Socks and Chains, optional.

**Steer Tires:** 21 x 8-9 Solid-Pneumatic Traction Tread mounted to a Fully Suspended Steer Axle.

**Lighting:** Dual Forward and Aft LED Headlights, Four Flashing Amber LED Running Lights and Amber Strobe Light mounted Center Rear. LED Brake Lights/Turn Signals, optional.

**Operator's Compartment:** Operator and Passenger Seats, Forward Facing, Premium Grade including Armrests (Available in Black or Light Gray). Operator's Seat features a Fully Suspended, Adjustable setting for height, fore/aft and weight. Seat Belts, Dual Facing Operator's Helm and Cab with Heater, Defroster, and Windshield Wipers, optional.

**Camera and Monitors:** Camera at Aircraft Interface Area, with Color Monitors at "A" and "B" Station, optional.

**Construction:** Welded Steel Plate and Polymers preserved by Primer and Automotive High-Gloss Red or White Enamel Paint with special protective Polyurethane Coating to prevent rust, scratches and corrosion. Steel Rub Rails protect from side impact. Custom colors, optional.

#### SPECIFICATIONS:

Length .....	213.0 in / 541.0 cm
Width .....	82 in / 208.3 cm
Height (At lowest steering tilt setting) .....	37 in / 94 cm
Turning Radius .....	180 in / 457 cm
Wheel Base .....	92.2 in / 234.2 cm
Vehicle Speed, Empty .....	9 MPH / 14.5 KPH
Vehicle Speed, Loaded (To max. Vehicle Capacity) .....	4 MPH / 6.4 KPH
**Lift Cradle Capacity .....	12,000 LBS / 5443 KG
Nose Gear Cradle Lifting Height .....	9 in / 23 cm
Ground Clearance .....	5 in / 12.7 cm
Shipping Weight w/o Batteries & Charger .....	5330 LBS / 2418 KG
Shipping Weight w/ Motive Batteries & Charger .....	9400 LBS / 4264 KG
Shipping Weight w/ Motive & GPU Batteries & Charger .....	9750 LBS / 4423 KG

\*\*Lift Capacity is calculated with 20 in / 51 cm diameter aircraft tire in lift cradle. Aircraft tire center line at 23 in / 58 cm from drive tire center line.

#### ADDITIONAL OPTIONS:

Draw Bar Pin, Specialized Aircraft Towing Adapters and Custom Highlift Adapters are available (consult factory). Illustration may show some optional equipment.

\*LEKTRO reserves the right to make changes and improvements in products and specifications without notice or obligation.

PATENT Nos. 5,151,003 / 5,302,075 / 9,067,691.

Other Patents Pending.

# LEKTRO

## Model AP8850SDA-AL-100

### AIRCRAFT TOWING VEHICLE

FOR AIRCRAFT UP TO 120,000 LBS/54,432 KG

1190 S.E. Flightline Drive, Warrenton, Oregon 97146-9692

1-800-535-8767 • 503-861-2288 • Fax 503-861-2283

E-mail: sales@lektro.com

http://www.lektro.com

